

# SUBMETER MULTIPOINT MODULE

## Quick Start Installation Guide

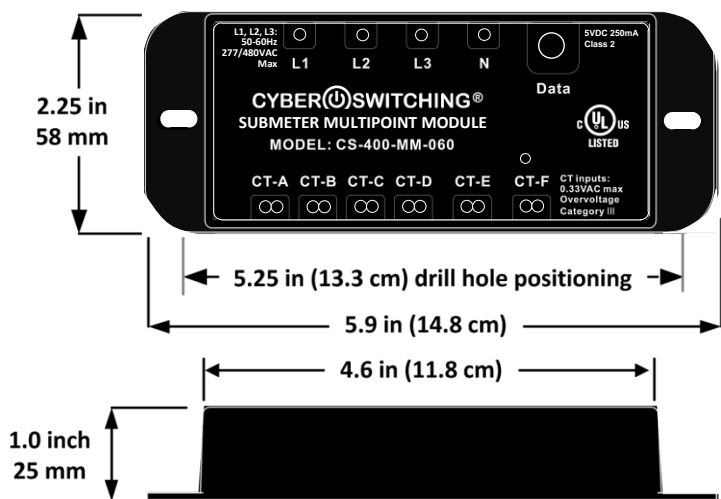

**Fig 1: Dimensioned views , Multipoint Module  
(leadwire cables not shown)**

**MODEL NUMBER:** CS-400-MM-060

### UNIT RATINGS:

Input ratings: 277/480Vac 250 mA  
50-60Hz, 55°C maximum ambient



Indicates presence of potentially harmful electrical shock hazards. De-energize circuit and consult instruction prior to operation.



LISTED  
E470543



## WARNINGS:



- 1. The 3-Phase Submeter Module is to be installed by a licensed electrician. Read all warnings and review instructions prior to initiating installation**
2. Installation and setup of network by qualified technicians only.
3. Install all equipment following NEC wiring codes, safety procedures and local electrical standards.
4. Submeter Module is an open type device intended for installation into UL rated electrical cabinet.
5. For the electrical system being monitored, ensure the neutral of the main input supply (mains) is earthed according to applicable NEC standards.
6. De-energize the installation on which the current is measured during application and removal of the current sensors.
7. Current sensors and submeter module may not be installed in a cabinet where they exceed 75% of the wiring space of any cross-sectional area within the cabinet.
8. If the equipment is used in a manner not specified by Cyber Switching the electrical protection and function provided by the equipment may be impaired.
9. Equipment intended for installation in restricted access location.
10. Disconnect all power supply cords before servicing.
11. Voltage sense, and neutral leadwires are required to be connected at circuit breakers or other fused connection. Ensure breaker is placed near module for convenient disconnection of unit.

## REQUIRED FOR INSTALLATION:

1. Mounting screws or equivalent to secure module.
2. RJ45 ethernet network cable.
3. Submeter OTG program cable (PN 1014013).
4. Laptop, with "Submeter Multipoint hub configuration tools.zip downloaded from Cyberswitching.com. Extract and install Submeter Multipoint\_Config.exe and launch prior to installation of module.
5. Submeter Multipoint Hub (Model CS-400-SH-MP, purchased & installed separately)
6. Current Transformer, 50-600A, Cyberswitching (purchased & installed separately)

## HARDWARE INSTALLATION:

1. See schematic view (pg. 3) for reference views showing typical installation of module and CT-coils (not included) for single phase, three wire and three phase circuits. See figure 4 and 5 for subpanel and electrical cabinet installation requirements.
2. Determine location to mount submeter module inside electrical cabinet, drill clearance holes for CT coil and voltage sense (if used).
3. Drill a 7/8" hole in side of electrical box for securement of panel mount Data/Power Connector (see figure below).
4. Install module, connect lead-wires for CT-coils and reference voltage. See figure 2 for identification of leadwires. Secure panel mount Data/Power connector to 7/8" clearance hole. Ensure wire placement inside panel is as per local electrical codes and listed warnings.
5. Use RJ45 Ethernet network cable to connect from panel mount RJ45 to an available meter port on the Multipoint Submeter hub (see figure 4 and 5, hub sold separately).
6. After hardware installation is complete, proceed to software configuration section of guide.

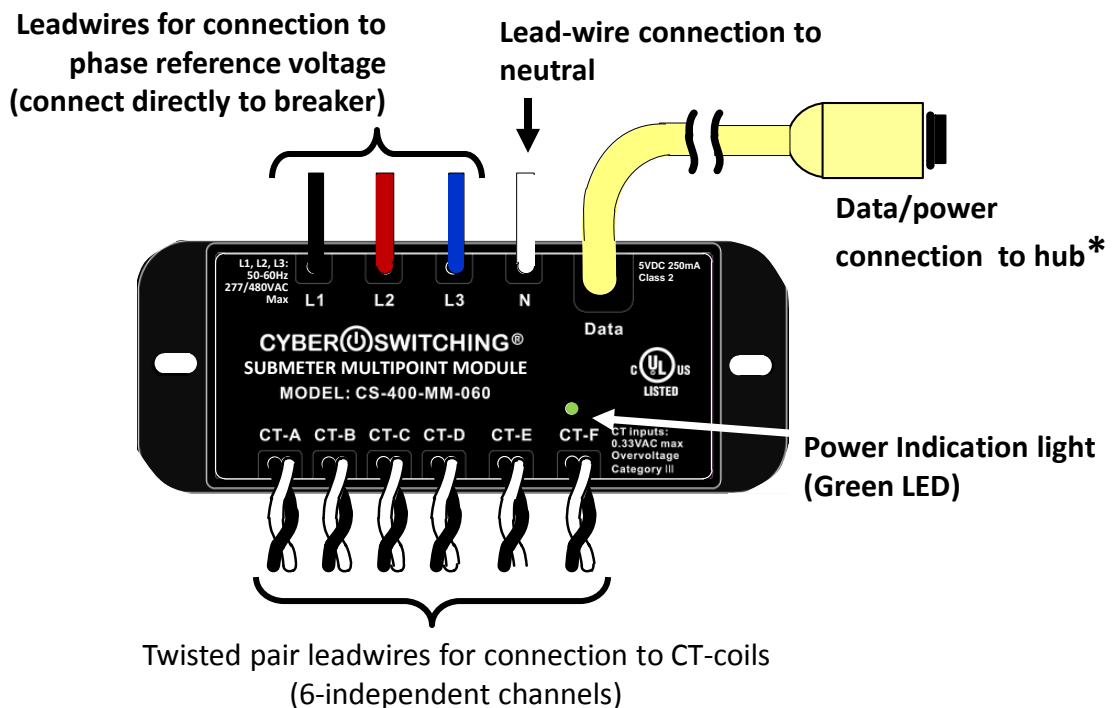

**Fig 2: Multipoint Unit, identification of leadwires.**

**Installation to monitor  
Single phase circuit**

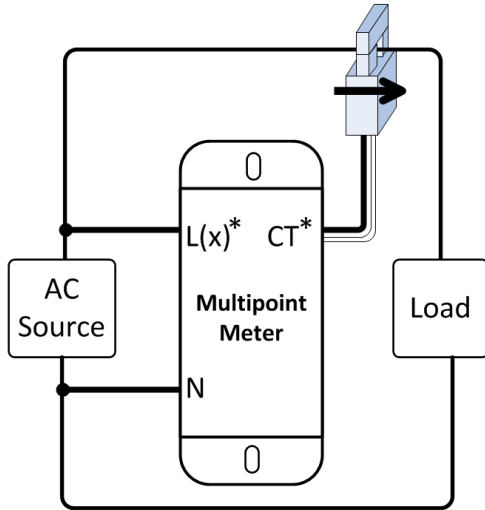

\*L(x) can be L1, L2, or L3  
CT can be CT-A, -B, -C, -D, -E, or -F

**Installation to monitor  
Single phase, 3-wire circuit**

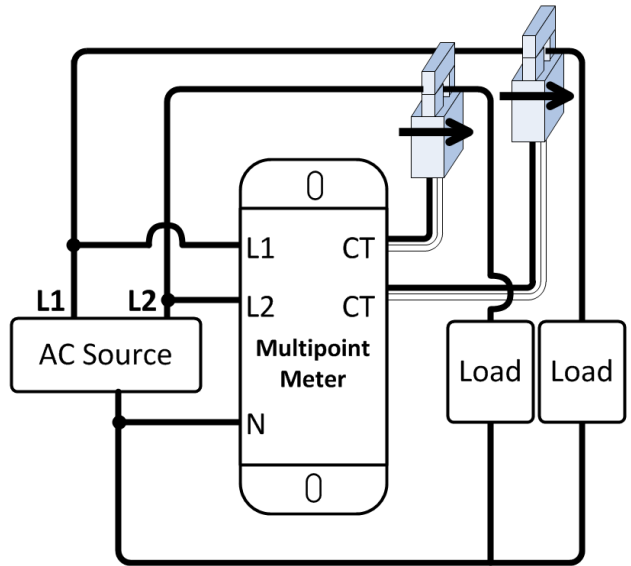

**Installation to monitor  
Three phase circuit**

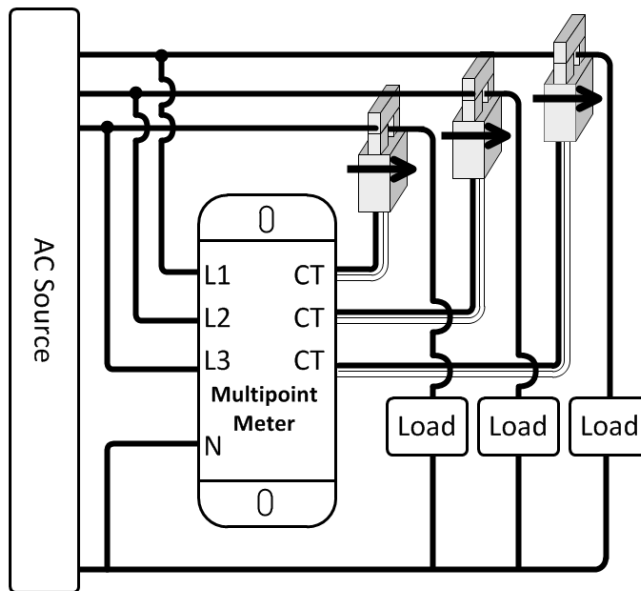

**Figure 3: Schematic for typical installation**

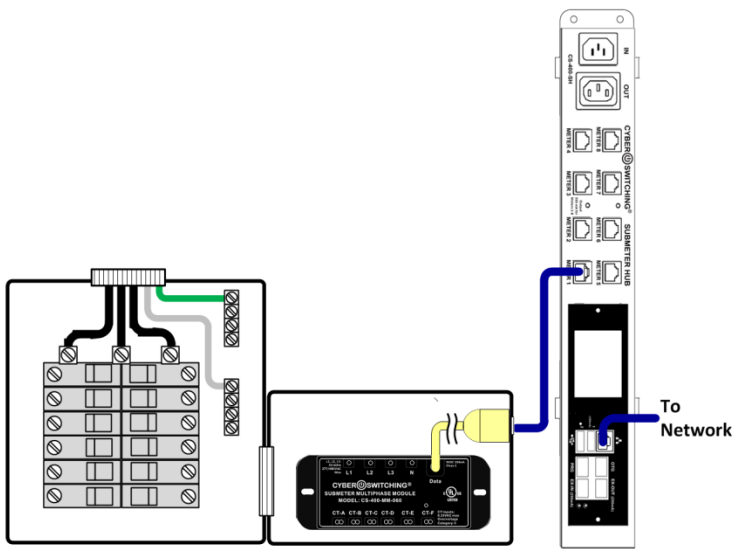

**Figure 4: Typical submeter module installation inside separate box outside electrical subpanel (1,2)**

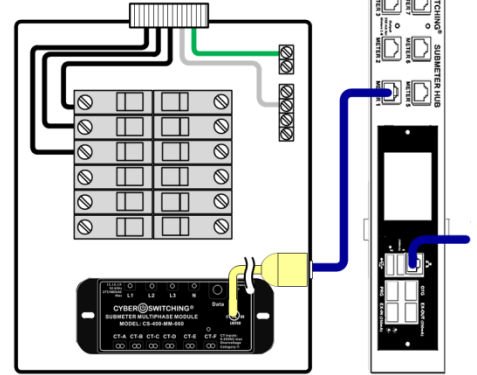

**Figure 5: Typical installation of unit using an electrical cabinet (1)**

- (1) Submeter module leadwires not shown in figure.
- (2) Not UL approved for installation at service entrance or in manufactured distribution panels unless specified as an approved accessory in Appendix A.

## **SOFTWARE CONFIGURATION:**

NOTE: Review Multipoint Submeter System User Manual (document 770-00005) prior to installation for detailed description and views for all configuration settings. See [Cyberswitching.com](http://Cyberswitching.com) for download version.

1. When initiating configurations, complete the following checks:
  - If configuring multiple submeter module with a hub, connect and configure one module at a time.
  - If hub already has a module assigned to meter port 8, temporarily disconnect this module while configuring the new unit.
2. Connect the RJ45 end of the OTG cable to the OTG port on submeter hub, connect USB end to programming computer.
3. Launch Multipoint\_Config.exe on laptop. On main screen of the Configuration Tool window, select Refresh to connect to Multipoint meter, then select Rescan Meter Mode to display default meter settings.
4. Select the newly installed Multipoint module (default ID is meter ID#8) to display the default settings.
5. Change Meter ID to match the submeter port number the meter is connected. Select the Apply button then power cycle module by briefly disconnecting Ethernet connection to hub (saves settings to flash).
6. In the configure settings of the main Configure tool window, update CT coil values for each channel. Use the drop down menu to select installed CT-coil current value if different from default settings. Press Apply and power cycle to save settings.
7. Default Voltage setting is "automatic" and is used if voltage sense leadwire are connected. If manually setting reference voltage deselect the automatic setting and type in value. When all channels assigned press apply and power cycle.
8. Select Voltage Sync function if assigning meter to receive voltage information from a source Multipoint meter directly connected to voltage. When enabled, reference voltage connection for the configured Multipoint meter is not needed.
9. Select the Store kWh function if required to set a specific value for the installed meter. kWh can be reset for each channel.
10. Exit program.
11. Log onto submeter hub and confirm installed meter is configured and monitoring circuit as intended.